



Style book of the Estonian Rescue Board

Vehicle marking guide

2024

Introduction

The style book of the Rescue Board is a document that includes the rules for using the visual material of the Rescue Board.

The aim of the style book is to ensure a uniform design for all Rescue Board materials (including vehicles), thus creating a recognisable and easy-to-use visual language.

This document is primarily a work tool for rescue vehicle designers and those putting the markings on the vehicles.

When designing the markings of the vehicles of the Rescue Board and voluntary rescue organisations (legal entities participating in rescue work), it is mandatory to follow the rules given in the style book.

Content

Types of vehicles and vehicle parts • 4

Legal space requirements • 6

Corporate colours and their use • 7

Materials • 8

Main pattern • 9

General rules for using the pattern • 10

Typography and emblems • 13

Figures and instructions by vehicle type • 14

Voluntary rescue • 20

Inspiration / Examples • 21

Types of rescue vehicles

The fleet of the Rescue Board consists of vehicles of very different purposes, shapes, and sizes. The vehicles are broadly divided into four categories: long-cabin main vehicles, short-cabin tank and special vehicles, smaller command buses and vehicles, and special vehicles (trailers, crawler-type vehicles, etc.).

Main vehicle

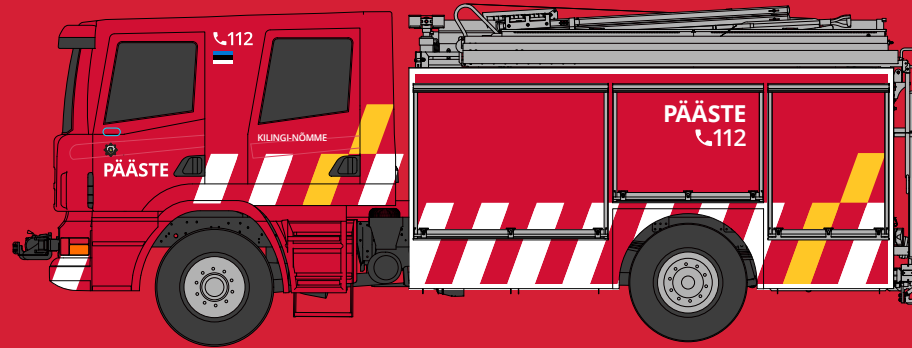

Tank vehicle

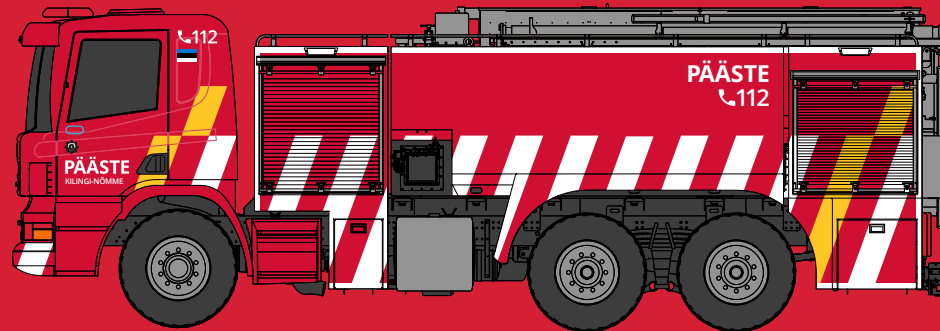

Command bus



Command vehicle



Distribution of vehicle parts

The basis of the unified marking is the division of vehicles to notional parts that share common design rules:

- A) short cabin (without crew compartment)
- B) superstructure, cargo, container, trailer
- C) long cabin (with crew compartment), van, passenger car

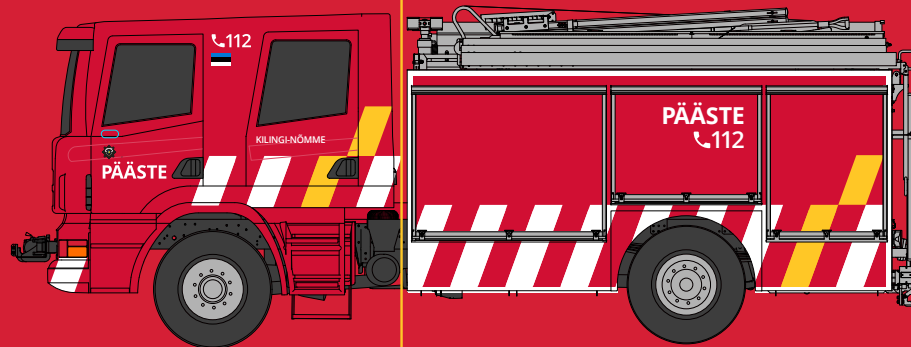
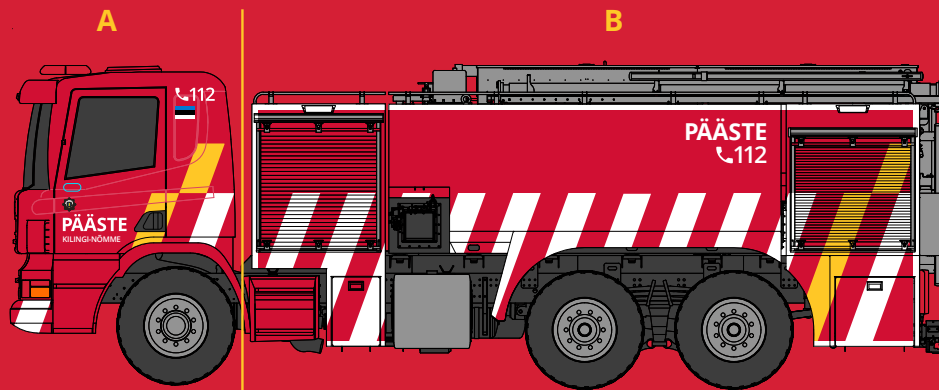

C

Legal space requirements

The design and technical solutions of the special marking of vehicles must be in accordance with the requirements established by '[The list of emergency and surveillance vehicles and, the procedure for their marking, and the applicable traffic rules](#)' (Regulation No. 77 of 16 June 2011 of the Government of the Republic) and '[Technical requirements and equipment requirements for motor vehicles and their trailers](#)' (Regulation No. 42 of 13 June 2011 of the Minister of Economic Affairs and Communications).

Contour and line marking of N-category vehicles

Type-specific visibility marking (position marking) must be in accordance with the shape and construction of the vehicle and follow the contour of the vehicle as closely as possible. The visibility marking must be located as close as possible to the edge of the vehicle (in yellow in the figures), which allows the length and width of the vehicle to be estimated when the lighting equipment of the vehicle is not switched on. The design elements of the special marking of the emergency vehicle must preserve the mandatory type-specific markings of the vehicle (the design elements **must not cover the contour and/or line markings of the vehicles or reduce their distinctiveness**).

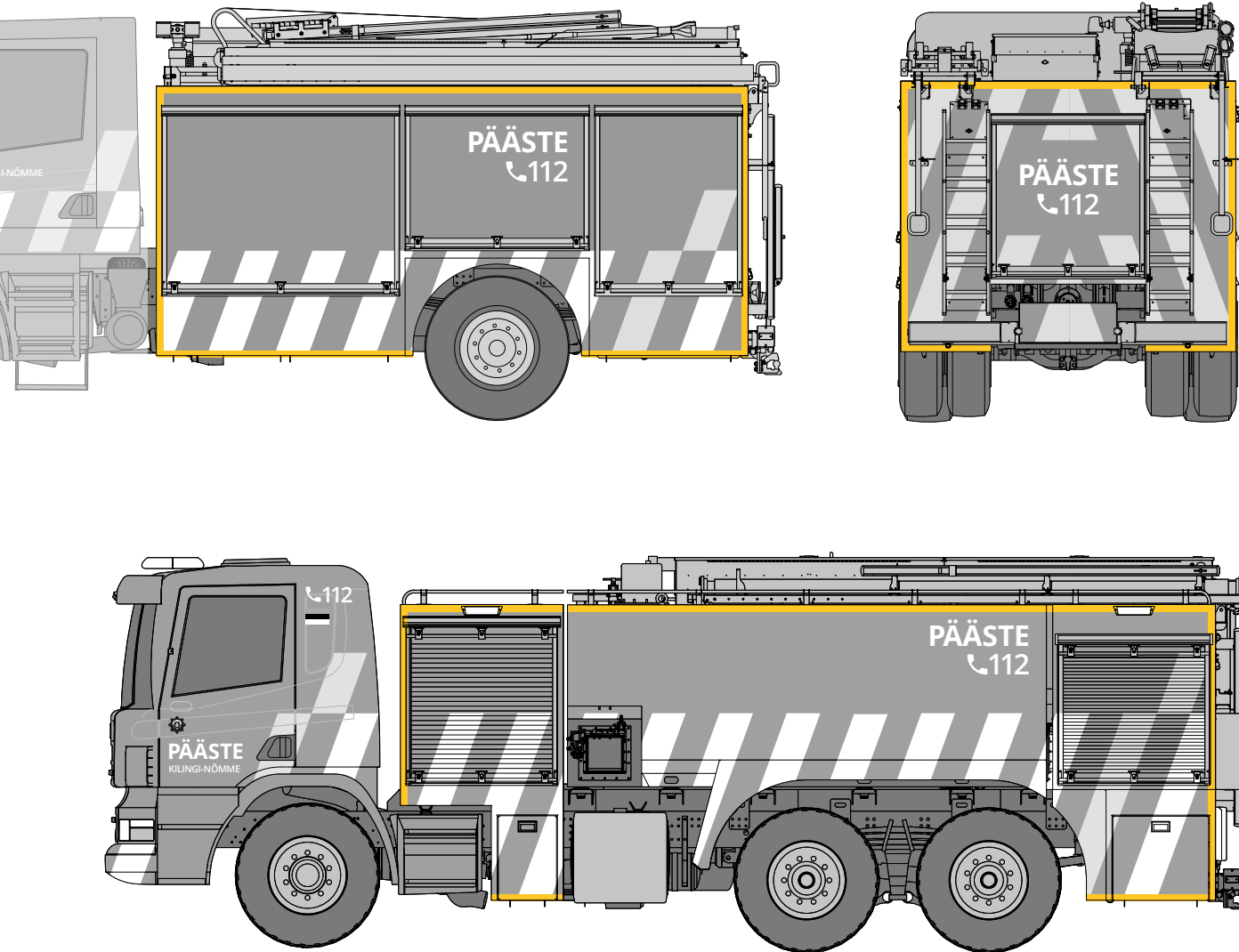

Corporate colours and their use

The distinctive colours of the Rescue Board are derived from the emblem of the Rescue Board, which uses the traditional colours of firefighting and rescue services.

Three base colours are used on vehicles:

- vehicle base colour signal red (RAL 3001)
- contrast colour traffic white (RAL 9016)
- contrast colour signal yellow (RAL 1003)



C11/M100/Y86/K2
R209/G15/B51
PMS 186
RAL 3001
HEX D10F33

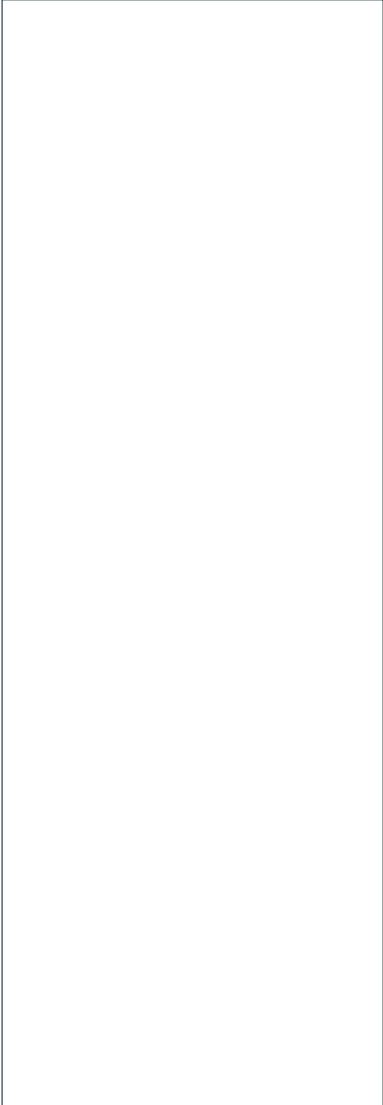

WHITE
R255/G255/B255
RAL 9016
HEX FFFFFFFF



C0/M22/Y93/K0
R255/G199/B38
PMS 123
RAL 1003
HEX FFC726

Materials

Low-relief (smooth) vinyl, UV-resistant, standard rate of wear resistance up to seven years.

Requirements for the material:

- reflectivity corresponding to the maximum allowed limit (**E-rule No. 104 class C limit**).
- The yellow colour must be close to the RAL 1003 (signal yellow) colour both in daylight and when illuminated. The use of neon yellow is not allowed.
- It must be possible to use the material to cover curved and multi-element surfaces so that it is not necessary to make a template for each piece (Diamond Grade materials are not suitable).
- The material must have an EU certificate of use and meet the established (product) parameters.

The corners of the stickers must be rounded.

White reflective material

Materials with both a honeycomb-based base pattern and uniform print resolution are allowed.



Yellow reflective material

Materials with both a honeycomb-based base pattern and uniform print resolution are allowed.

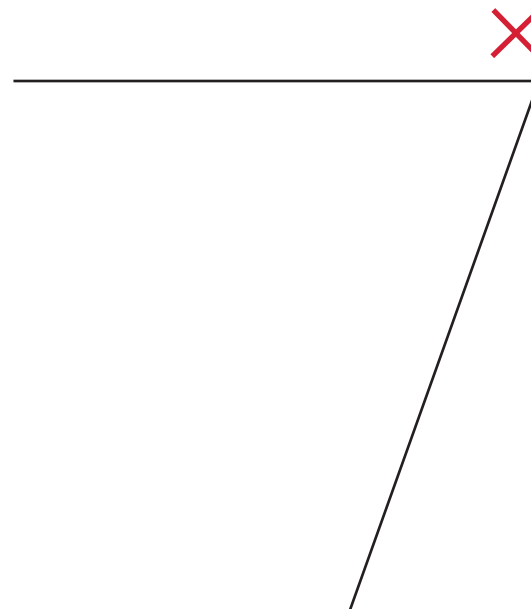
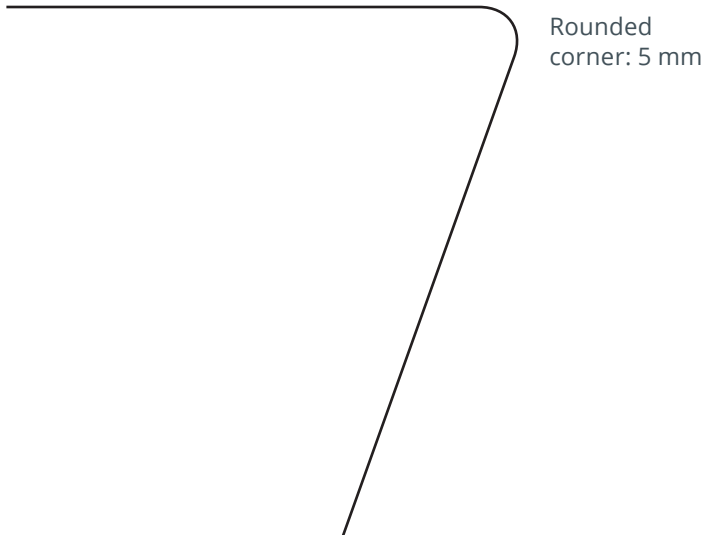

Main pattern

A single element

The common pattern of the vehicles consists of 25×45 cm rectangles, which are turned at an angle of 20 degrees so that the lower left corner of the shape points towards the front end of the vehicle (in the direction of traffic).

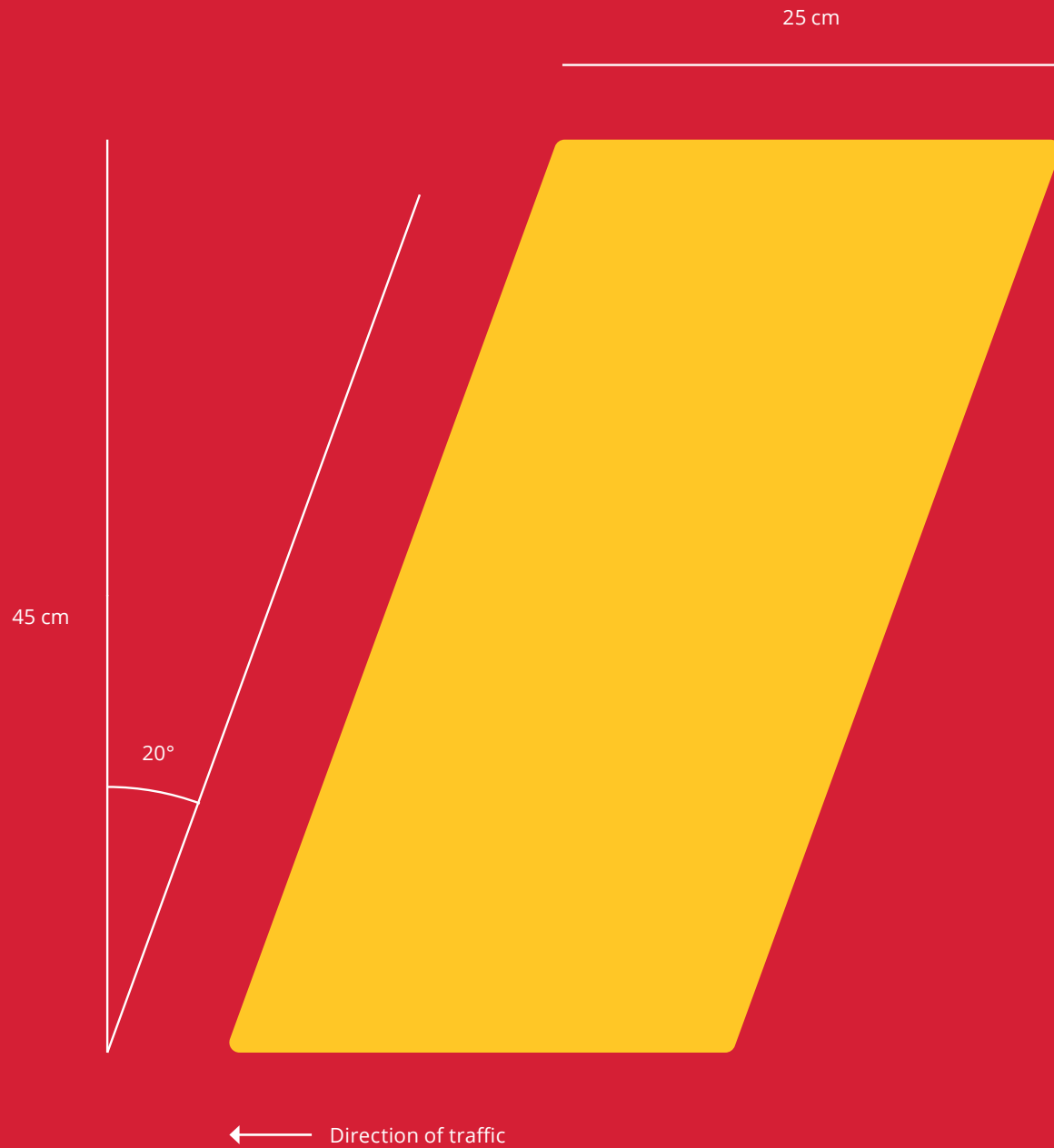

Main pattern

The individual elements form a symmetrical pattern on the lower edge of the vehicle. The pattern consists mainly of white rectangles and a pair of yellow rectangles at the rear of the vehicle adds character to it.

The single yellow rectangle above the main pattern should maintain an approximate height of 45 cm, whereas the height of the bottom row will vary according to the vehicle type and will take into account the specificities of the vehicle body panels.

The height of the outline of the main pattern (the lower row of diagonal stripes) must not exceed the horizontal centre line of the vehicle superstructure and/or cabin.



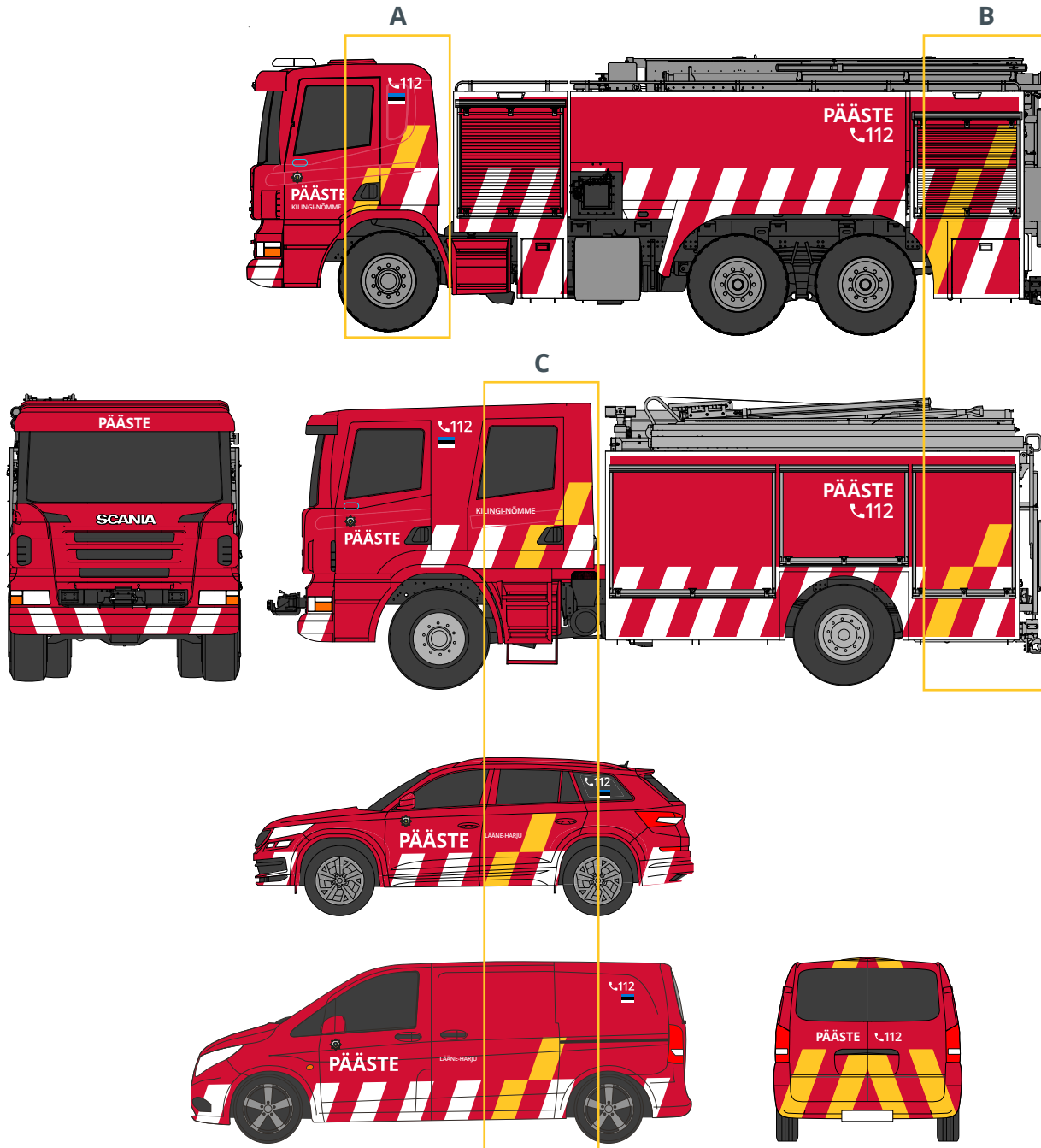

General rules for using the pattern

Side view of the vehicle

The structure outlined in the [distribution of vehicle parts](#) is taken into account in the placement of the pattern:

- A) only three rectangles are used on the short cabin: two yellow rectangles and one white rectangle
- B) on superstructures, cargos, containers, and trailers, the total length is covered with the pattern so that the yellow rectangles are located at the rear end of the vehicle.
- C) on long-cabin trucks, vans, and passenger cars, the pattern is placed in accordance with the vehicle type:
 - to the rear end of the long cabin so that the white rectangles extend to the door of the driver
 - on the command vehicle and bus so that the yellow rectangles do not extend beyond the rear wheel arch.

Front and rear view of the vehicle

From the front and side view, the pattern should follow a natural continuation: from the middle part of the front side, the pattern is divided into two halves in a “V-shape” and continues unbroken on the sides of the vehicle.

The diagonal lines at the rear of the vehicle start from the lower outer corners and are directed towards the vertical center line. The pattern covers the entire height of the rear of the vehicle, making it more visible in the dark.

The reflective marking on the rear does not extend to the rear lights, the distance between the rear light and the reflective material must be up to 20 cm (if it is necessary, a yellow non-reflective adhesive material can be used to continue the pattern).

No pattern is applied to the windows of the vehicle.

Frontal protection system

When the frontal protection system/bumper is used on the rescue vehicle, it is covered with a white contrasting colour (except for chromed surfaces) and no special reflective marking is applied to it.

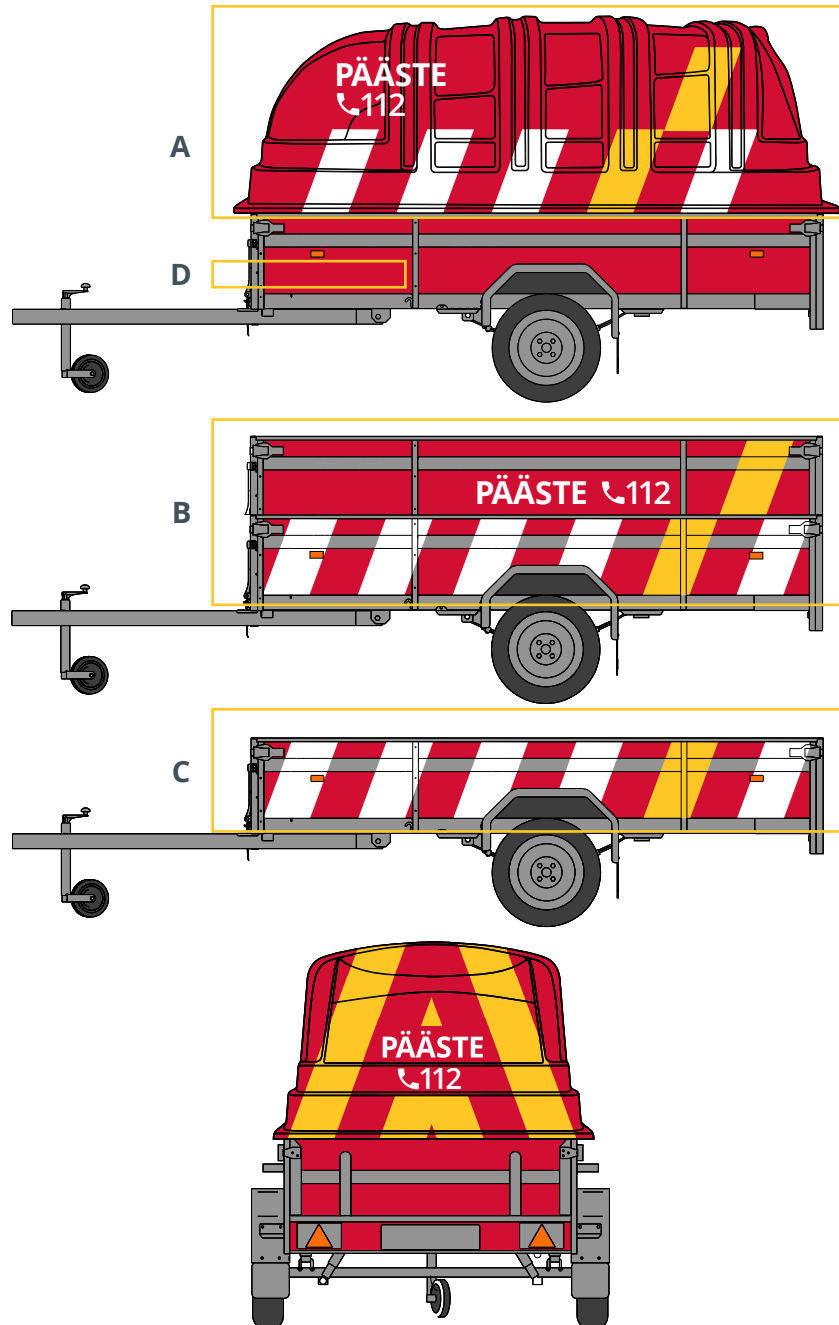

General rules for using the pattern

Trailers

- A) The undercarriage of light-weight trailers with a cover is not marked with special marking made of reflective material. The pattern of the special marking (or its fragments) is applied to the cover part. The undercarriage of the trailer does not have to be covered with the red base colour.
- B) For special trailers, the pattern of the special marking is applied to both the undercarriage and the superstructure (except trailers with a tarpaulin cover) similarly to the superstructure of N-category vehicles.
- C) A trailer without a cover and other trailers with a low side wall (height up to 40 cm) do not have to be marked with special markings and covered with the red base colour. The lower line of the special marking (white lines with one yellow line at the rear end of the vehicle) is applied to a trailer with a low side wall. The height of the special marking is determined by the height of the side wall of the trailer.
- D) On the undercarriage of the trailer, it is allowed to add the logos of the manufacturer or company on the rear wall panel in the lower right corner; on the side panel, the logos can be added in the direction of traffic in the first lower corner (the height of the inscriptions/logos must not exceed 9 cm). The height of the elements of the reflective special marking varies in accordance with the height of the side ports of the trailer or structural features.

The letter height of the word 'PÄÄSTE' is 9–12 cm (depending on the technical characteristics of the trailer or the height of the side wall). On narrow surfaces, it is allowed to place 'PÄÄSTE' and '112' next to each other on the trailer (see example), if this allows for a larger letter height.

Open Sans Bold

A B C D E F G H I J K L M N O P R S Š Z Ž T U V Õ Ä Ö Ü

0 1 2 3 4 5 6 7 8 9

Open Sans Semibold

A B C D E F G H I J K L M N O P R S Š Z Ž T U V Õ Ä Ö Ü

0 1 2 3 4 5 6 7 8 9



PÄÄSTE



KILINGI-NÕMME

Typography and emblems

Only **Open Sans Bold** and **Open Sans Semibold** fonts are used on the vehicles.

The font can be downloaded here:

fonts.google.com/specimen/Open+Sans

Open Sans Bold is used **only in the word 'PÄÄSTE' and for the signal letters on the roof of the vehicle**. Other texts are written on the vehicle in the Open Sans Semibold font.

Capital letters are used throughout on the vehicles.

A maximum of three different text sizes are used on one vehicle (excluding the roof of the vehicle, where a maximum large font size is allowed). The largest text size is always used for the word 'PÄÄSTE', followed by '112'. The smallest font size is used to mark the region.

Emblems

The emblem of the Rescue Board is always located **in the upper corner of the first door of the vehicle (when viewed in the direction of traffic), under the rear-view mirror**.

In addition to the Rescue Board emblem, the vehicles also have an image of the Estonian flag. It is always located under the phone icon and the phone number '112'. The size of the flag is 50% of the width of the phone icon and the phone number '112' (the ratio of the length and width of the flag image is 7 × 11 units). Symbols characteristic of a specific rescue brigade (e.g. historical logo, Eliitkomando rescue brigade sticker, etc.) can be placed on the **B-pillar of the cabin part of the main vehicle**, under the phone number '112' and the image of the Estonian flag.

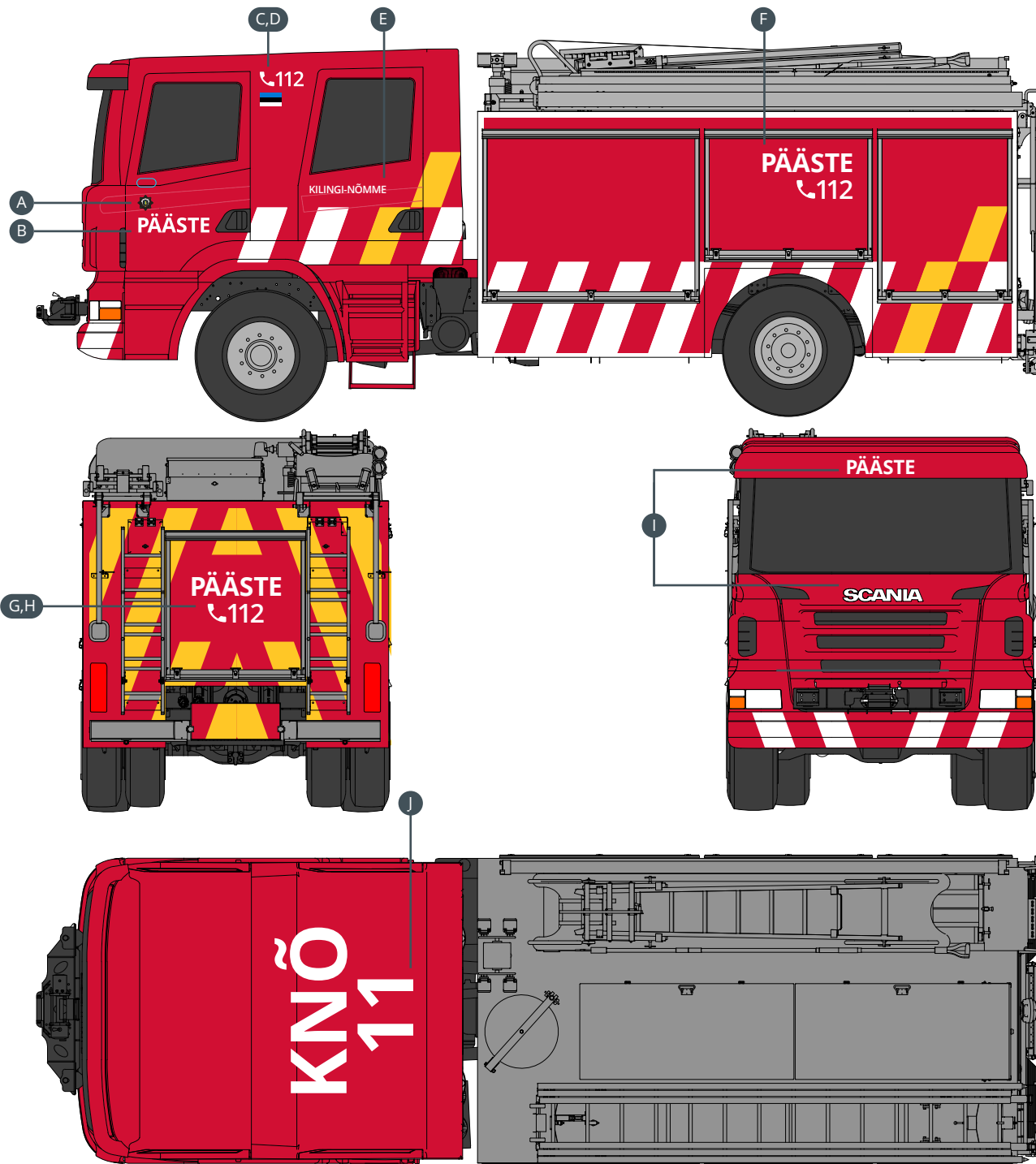

Main vehicle in 1:50 scale

On the front doors of the cabin:

- A) Emblem of the Rescue Board (12 × 12 cm)
- B) The word 'PÄÄSTE' (height of the letter 'P' is 12 cm)

Between the cabin doors on the upper edge of the vehicle:

- C) Phone icon and the phone number '112' (height 12 cm)
- D) Estonian flag (width 17.5 cm, height 11.14 cm)

On the rear doors of the cabin:

- E) Name of the rescue brigade (letter height 6 cm) NB! The height of the letter is measured by a letter without dots.

On the middle panel of the superstructure:

- F) 'PÄÄSTE' (the height of the letter 'P' is 15 cm)
Phone icon and phone number '112' (15 cm)

Centre of the rear of the car:

- G) 'PÄÄSTE' (height of the 'P' is 15 cm)
- H) Phone icon and the phone number '112' (height 15 cm)

At the front of the vehicle:

- I) The word 'PÄÄSTE' (height of the letter 'P' is 12 cm) above the front window or on the front panel

Cabin roof

- J) The signal letters are placed on the rear third of the roof of the vehicle in a size that can be read from the helicopter/drone

It is allowed to add safety messages necessary to achieve the goals of the Rescue Board on the sides of the vehicle (the first side hatches of the superstructure located behind the cabin). When adding safety messages or information stickers, the visual entirety of the special marking of the emergency vehicle must be preserved.

Reflective materials of the main vehicle

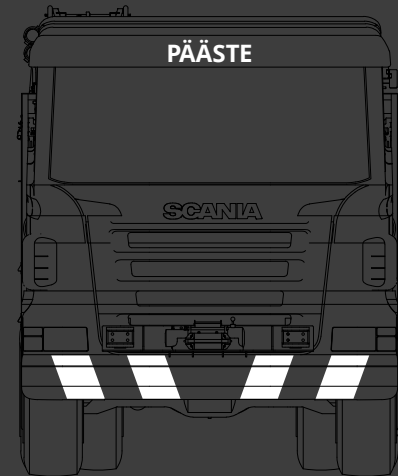
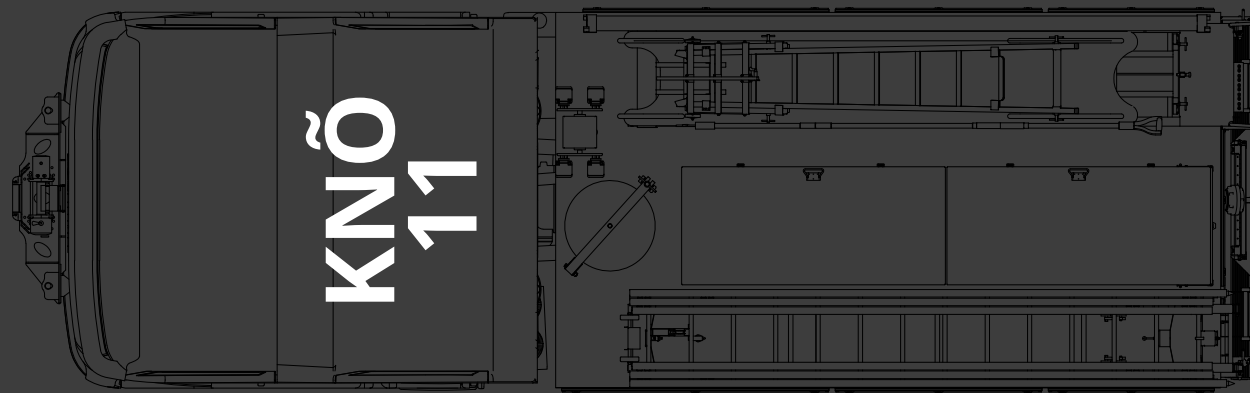
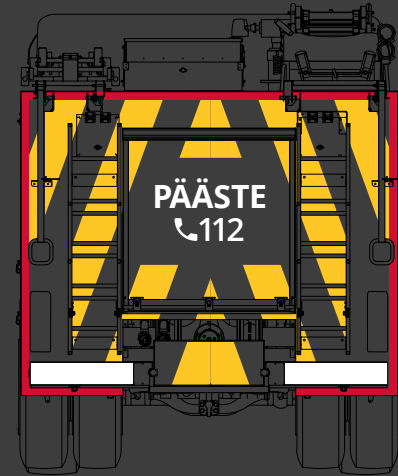
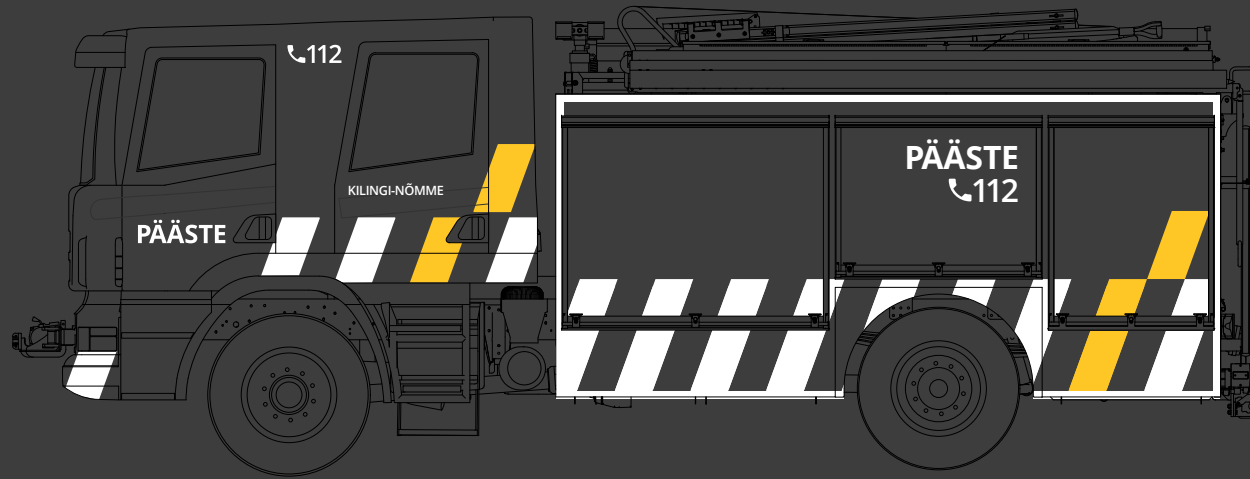

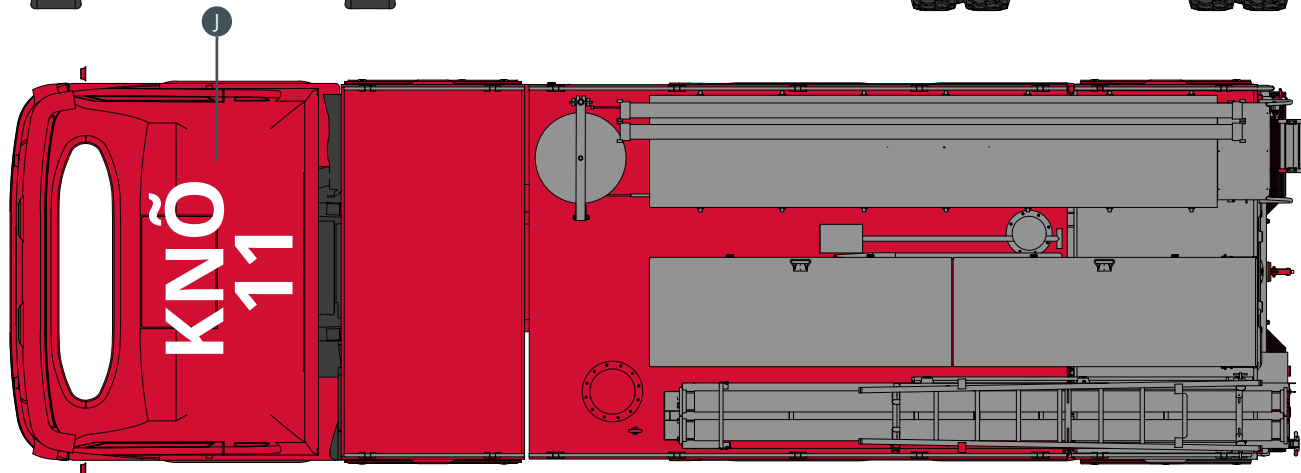
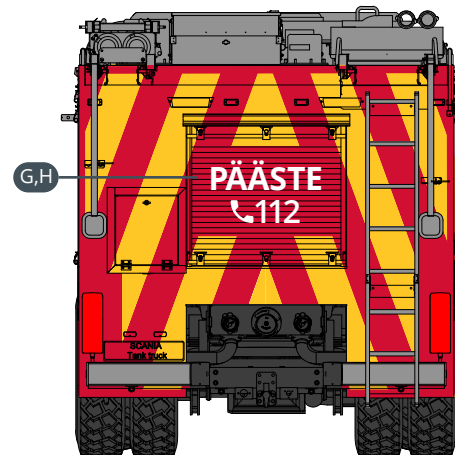
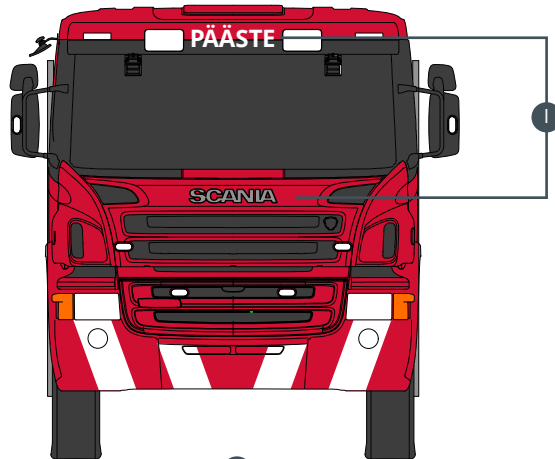
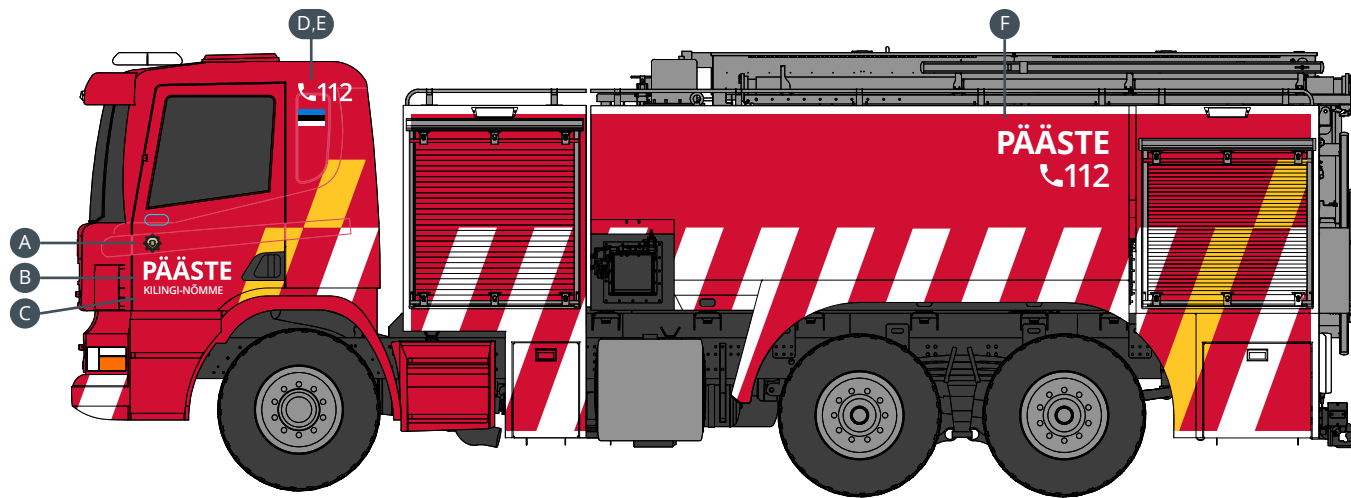

Tank vehicle 1:50

On the doors of the cabin:

- A) Emblem of the Rescue Board (12 × 12 cm)
- B) The word 'PÄÄSTE' (height of the letter 'P' is 12 cm)
- C) Name of the rescue brigade (letter height 6 cm, 5 cm allowed for longer names)

NB! The height of the letter is measured by a letter without dots.

Behind the cabin doors on the upper edge of the vehicle:

- D) Phone icon and the phone number '112' (height 12 cm)
- E) Estonian flag (width 17.5 cm, height 11.14 cm)

At the rear edge of the middle panel of the superstructure:

- F) 'PÄÄSTE' (the height of the letter 'P' is 15 cm)
Phone icon and phone number '112' (height 15 cm)

Centre of the rear of the car:

- G) 'PÄÄSTE' (height of the 'P' is 15cm)
- H) Phone icon and the phone number '112' (15 cm)

At the front of the vehicle:

- I) The word 'PÄÄSTE' (height of the letter 'P' is 12 cm) above the front window or on the front panel

Cabin roof

- J) The signal letters are placed on the rear third of the vehicle in a size that can be read from a helicopter

Reflective materials of the tank vehicle

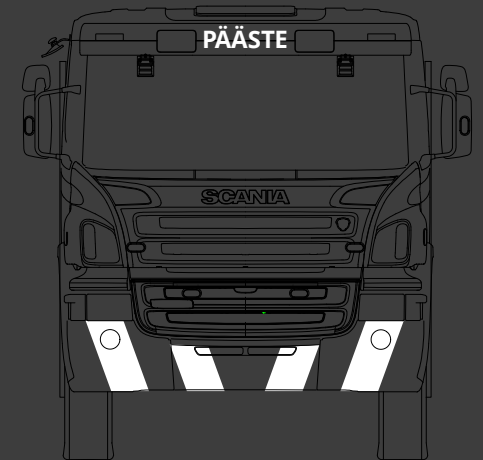
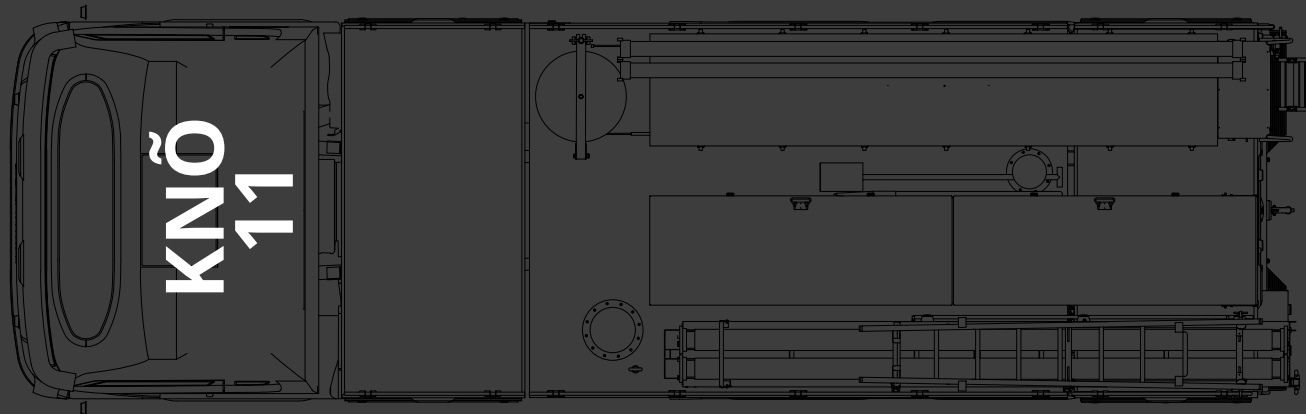
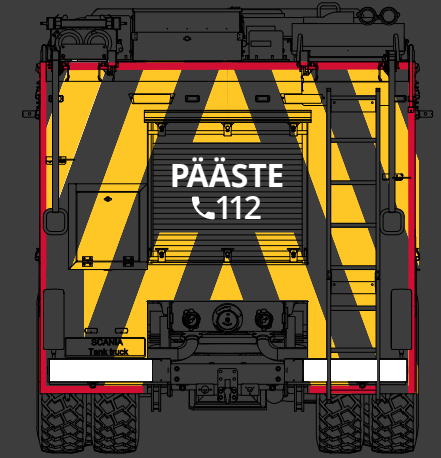
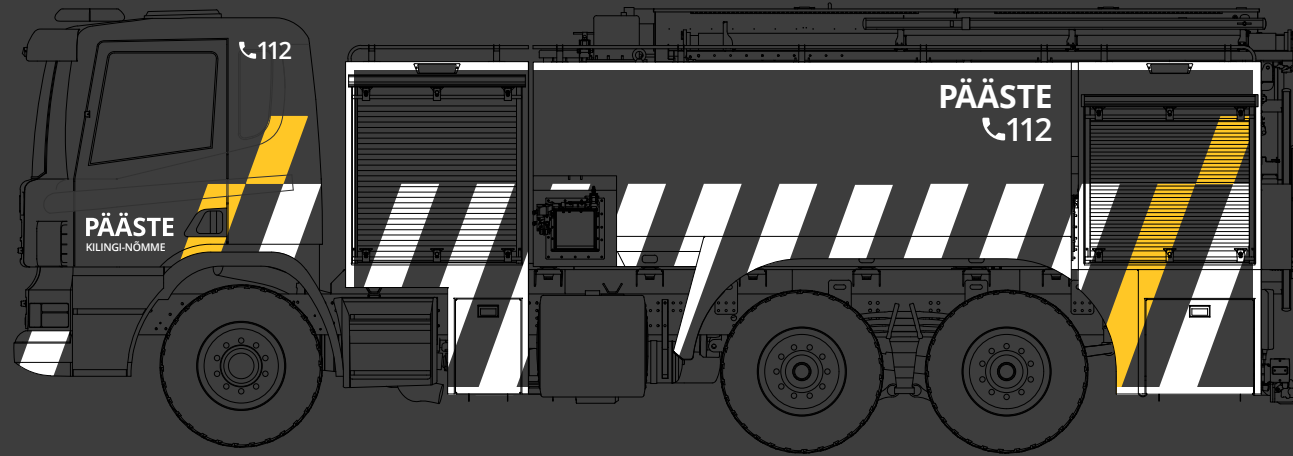

Command vehicle and bus 1:50

On the front doors:

- A) Emblem of the Rescue Board (12 × 12 cm)
- B) The word 'PÄÄSTE' (height of the letter 'P' is 15 cm)

On the rear doors:

- C) Name of the command group (letter height 3.75 cm, 3 cm allowed for longer names)
NB! The height of the letter is measured by a letter without dots.

On the rearmost side window of the vehicle and at the rear end of the bus

- D) Phone icon and the phone number '112' (height 9 cm)
- E) Estonian flag (width 13.1 cm, height 8.4 cm)

On the rear side above the registration plate:

- F) Passenger car: the word 'PÄÄSTE' (height of the letter 'P' is 7 cm or what is possible)
- G) Passenger car: phone icon and the phone number '112' (height 7 cm or what is possible)
- H) Command bus: the word 'PÄÄSTE' (height of the letter 'P' is 9 cm or what is possible)
- I) Command bus: phone icon and the phone number '112' (height 9 cm or what is possible)

On the hood of the vehicle:

- J) The word 'PÄÄSTE' (height of the letter 'P' is 15 cm)

On the roof of the vehicle

- K) The signal letters are placed on the rear third of the roof of the vehicle in a size that can be read from the helicopter/drone

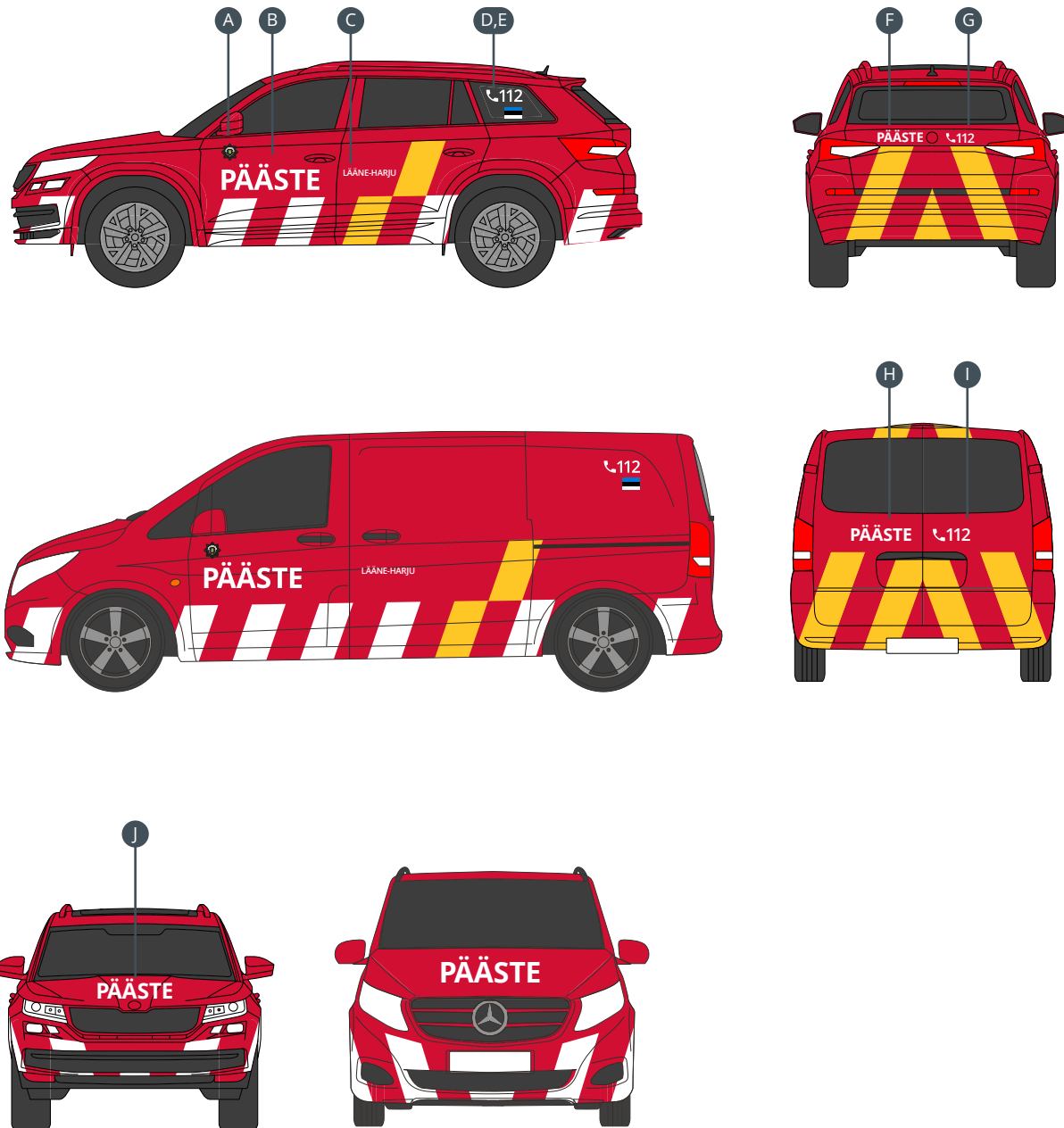

Reflective materials of the
command vehicle and bus

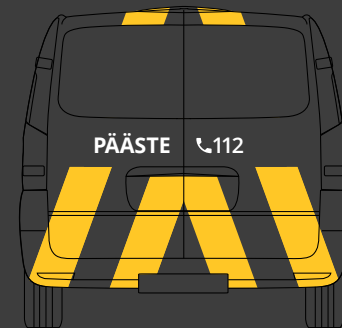

Voluntary rescue

The vehicles of volunteer rescuers are based on the same principles of special marking with the following exceptions:

- The emblem of the volunteer rescue organisation is used instead of the emblem of the Rescue Board
- The prefix 'VABATAHTLIK' is added to the word 'PÄÄSTE'

The size of the letters of the word 'PÄÄSTE' on the cabin should be based on the rules of the main vehicle – the height of the letter 'P' is 12 cm and the height of the smaller word 'VABATAHTLIK' is 6 cm.

If, due to the specifics of the vehicle, the word 'PÄÄSTE' cannot be 12 cm high, the size of the word 'VABATAHTLIK' should also scale with it. The height of the smaller word is always 50% of the height of the larger word.



Inspiration / Examples



Inspiration / Examples







Inspiration / Examples



Inspiration / Examples

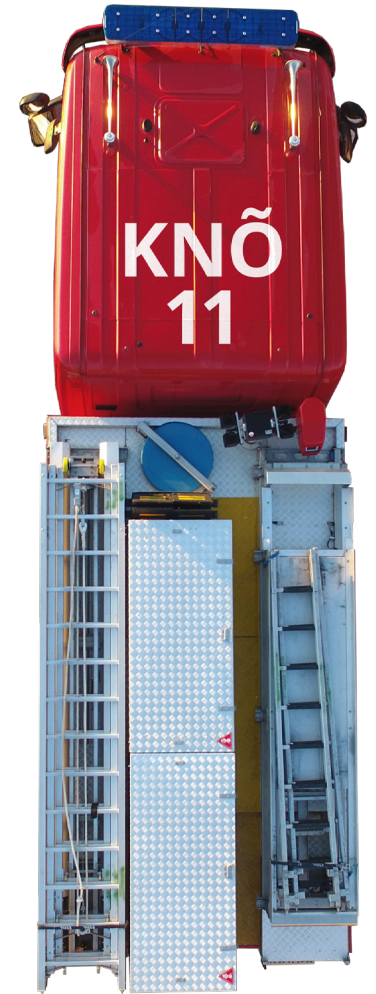



Inspiration / Examples

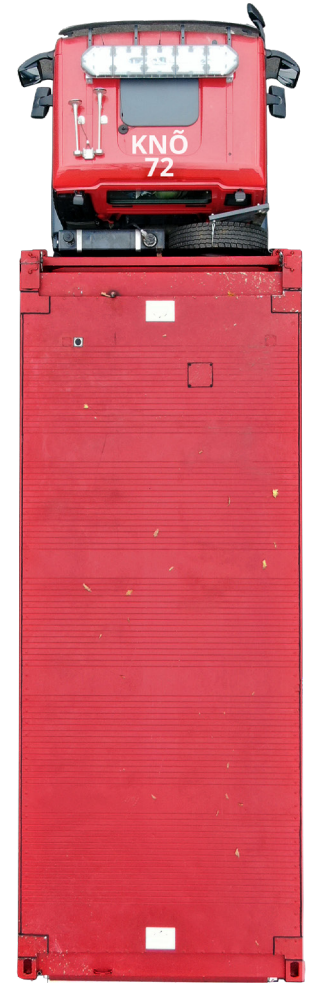

Inspiration / Examples



Inspiration / Examples





Inspiration / Examples



Inspiration / Examples



